

Modular Antenna Panel for King Air 200 and 300 Series Aircraft

FAA STC No. SA04459CH

EASA STC NO. 10077043

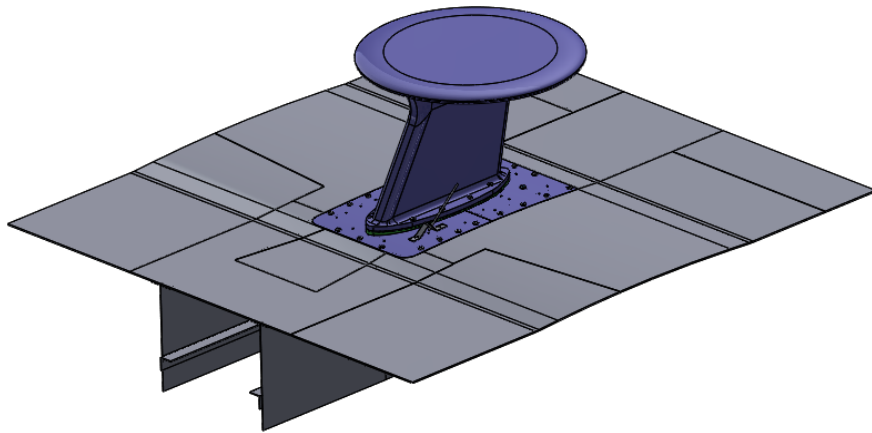

Plug and play solution for tail-mounted antennas on King Air 200 and 300 series aircraft. STC provides anticollision light relocation and mounting of several antennas including VHF/UHF Satcom and GPS antennas (dual mounting). Modular design allows for quick adaptation for other antenna installations.

The panel easily replaces the horizontal stabilizer cover, P/N 101-62026-1, which currently houses the anticollision light.

- Creates Tail Structural Real Estate
- Simplifies Antenna Installations
- Maintains Existing Maintenance Accessibility

STC Purchase Includes

- STC'd Panel w/ Hardware
- Antenna Adapter plate(s)
- Av-DEC Gaskets
- Anticollision Light Relocation Structure, Hardware, and Instl Dwg
- FAA-Approved Instructions for Continued Airworthiness (ICA)
- STC Permission for Use per 14 CFR 21.120

Operator Provides

- Anticollision Light Relocation Labor (est. 6-8 Hrs)
- Panel Installation
- Antenna(s)
- Consumables (Sealants, Topcoat, etc.)

